

CONNOISSEUR MODELS

- 0 Gauge -

LNER 12 Ton Lowfit Wagon

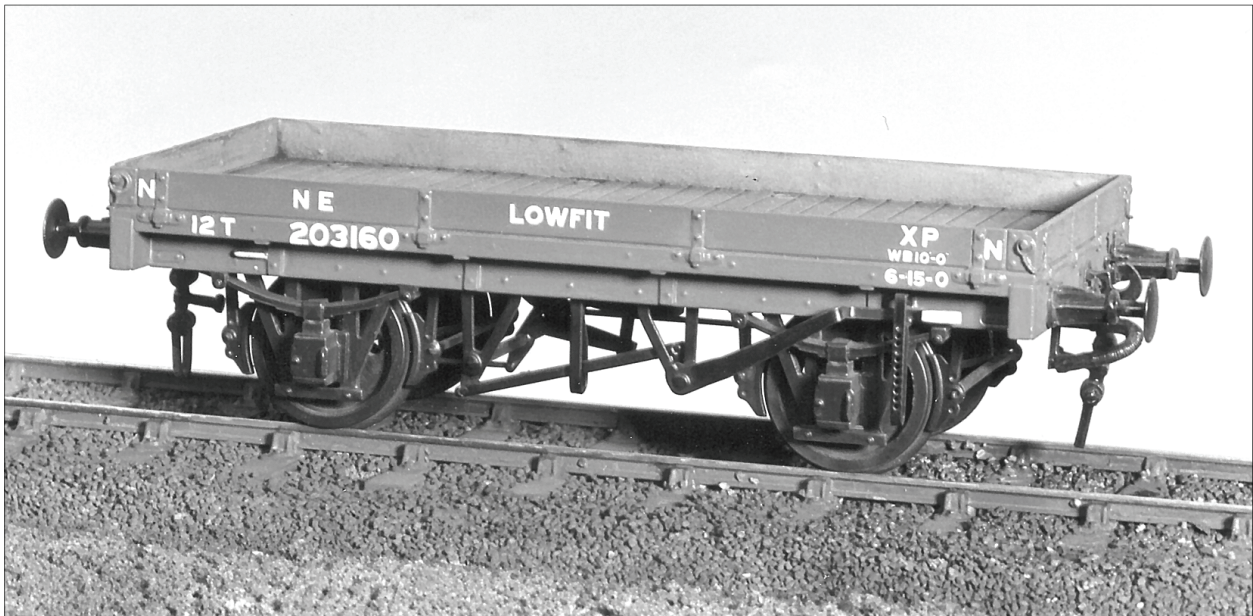

PROTOTYPE. In the mid thirties the LNER built nearly 1,400 single plank, vacuum brake fitted wagons with all four sides hinged at the bottom. They carried a large variety of loads but were particularly useful for small road vehicles such as farm tractors as with the end dropped they could be driven from an end loading dock onto the wagon.

KIT. There is some clever interlocking of the etched components. Lots of detail overlays for hinges etc, push out rivets and white metal components for the fitted brake gear. If you wanted a variety of components and techniques to provide practice for your soldering skills, then this kit has got the lot.

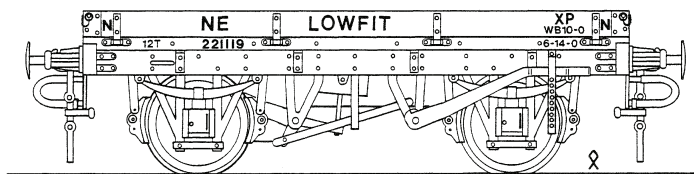

Wheels are required to complete. 3'1", 3 hole disc Wagon Wheels (Slater's Catalogue Number 7122). Available From Slater's Plastikard, Temple Rd, Matlock Bath, Matlock, Derbyshire, DE4 3PG, Telephone 01629 583993.

**Connoisseur Models, 33 Grampian Road, Penfields,
Stourbridge, DY8 4UE, Telephone 01384 371418**

GENERAL INSTRUCTIONS

Please read this section carefully, especially if this is your first etched brass kit. Many modellers fight shy of working in this medium, but the basic skills are relatively easy to acquire. Once you've learned how to form and solder brass, you'll find all kinds of modelling possibilities will open up for you.

Assembling an etched kit involves exactly the same skills that a scratchbuilder uses – the only difference is that the cutting out of the parts is already done for you. Some filing and trimming will, however, be necessary from time to time. Where this is the case, I have highlighted it in the instructions.

The main skill to master is soldering and I would recommend a Weller 40 Watt soldering iron. This has a 6mm diameter, removable copper bit. The bit is shaped like a screwdriver and has a bright coating of solder (tinned). This combination of iron and bit shape is ideal for running fillet joints and has a good reserve of heat, that is necessary for soldering small parts on to large components. Note the shape and condition of a new bit, as this won't last long and will need restoring back to this condition.

It is important to keep the bit clean and in good condition as you work. Get a soldering iron stand containing a damp sponge; old oxidized solder is wiped off on this before picking up fresh solder for each joint. If you haven't made a joint for some time you may find that a hard black crust has formed on the bit. Remove this with a brass wire brush (suede brush) and then feed some multicore solder onto each side of the bit to restore a bright surface (referred to as wetting or tinning the bit). After about 8 hours use you will find the bit is in poor condition, with holes and a ragged edge. File the bit back to its original shape using a hand bastard file and then polish the surfaces on emery cloth. Coat the bit with Fluxite Soldering Paste (traditionally used by plumbers) and this will prevent the bare copper oxidizing as the iron heats up. Then feed multicore solder onto the bit to form a generous coating and leave to bubble away for a couple of minutes before wiping excess off to give a bit almost as good as new.

A smaller Antex 25 Watt iron with a 3.2mm screwdriver bit is very useful for small assemblies and detail work such as handrails, but will have insufficient heat reserve for main assembly work. The Antex has a plated iron bit, after a little use with 145° solder a grey oxide appears on the bit that will prevent you from picking up the solder. Touch the bit to some multicore solder and it will flash over the bit, wetting it so that you can continue picking up 145° solder. I have found no problems with mixing the two solders in this way.

I use 145° solder for virtually all assembly work. I prefer it in wire form but it is also produced in stick form by Carrs. I find that its lower working temperature helps to give a quick clean joint. Limiting the build up of heat in components, which may cause distortion. I find that I can hold parts together with my finger ends and make a joint before heat reaches my fingers or other etched parts drop off.

I use 60/40, tin/lead, fluxed multicore electrical solder (melting point about 190°) mainly to keep the iron bits in good condition. As it gives a slightly stronger joint than 145° I sometimes use it for small spot joints on handrail wire, lamp brackets etc, but still use extra liquid flux.

For all brass and nickel silver work I use Carrs green label liquid flux. You will soon get the feel for how much to use but more problems are caused by too little flux than too much.

Before soldering components together, thoroughly clean both surfaces along the join line with a glass fibre burnishing brush. Using your tweezers or a knife blade etc, hold the parts together in the correct position and, with an old paintbrush, run some flux along the area to be joined. Still keeping the parts correctly aligned, pick up a small quantity of solder on the tip of your iron and carry it to the joint (unlike electrical soldering, when you feed solder into the joint). Hold the iron against the joint just long enough for the solder to flash between the parts. Don't let go of the parts until the solder has cooled – this takes from five to ten seconds. To run a fillet of solder along a joint, wait until the solder flashes between the parts and then pull the molten solder along

the joint with the iron tip. Don't load the iron tip with a lot of extra solder, but work the joint in 1" lengths, bringing in small quantities of solder. Brass is a very forgiving material and if you get something out of alignment, use heat from the iron to desolder the joint before starting again. For complicated assemblies, it is a good idea to only tack solder parts together. You can then make adjustments by desoldering until you are happy with the location of parts and then solder solid.

When you need to laminate two or more layers of brass together, align the parts and carefully clamp them together, either in the vice or by holding them with miniature crocodile clips. Run flux around the edges, and then go around with the soldering iron. Clean up thoroughly afterwards.

To fit small parts and overlays on to a larger assembly, such as strapping to a wagon side, when you need to prevent finely detailed areas such as planking becoming clogged up with solder. Tin the back of the small component first, then hold in place on the model and apply flux. Carefully wipe the tip of your iron on a sponge to remove any solder from it (dry iron), and then touch it against the parts to be joined. After a few seconds you'll see molten solder bubbling from the edges. Remove the iron, still holding the parts in place, and allow the joint to cool. An alternative is to use solder paint (I would recommend Carrs 188 solder paste). As the name suggests, this is a flux and solder in one. Simply apply a thin coat of solder paint to the back of the component instead of tinning. Still apply a small amount of liquid flux before you solder the part into place.

Any surplus solder should be removed using a craft knife, I find No 10 curved scalpel blades ideal, then burnish clean with a glass fibre brush. With practice, you'll learn how to use the minimum amount of solder to do the job. Flux is corrosive so, after each soldering session, give your model a good scrub with washing up liquid or Jif. After a day or two, any remaining flux residues will show as a green film, which should be washed away.

To cut parts from the fret, use a sharp Stanley knife on a piece of hardboard or a pointed scalpel blade on a block of softwood. Remove tags and burrs with a fine file.

Three-dimensional parts are formed by folding. On an etched brass kit, the fold lines are normally half-etched on the inside of the fold. You'll be able to fold most parts using smooth-jawed pliers. For longer parts folding bars are desirable.

Other useful tools include a bench vice, a good pair of tweezers, a set of Swiss files (get a full set of cheap ones and then buy quality replacements for the three that you use the most), a pin vice with a selection of drills from 0.5mm to 2.1mm plus a few larger sizes that you use regularly (2.6mm for axle bearings etc), some square-nosed pliers and some very pointed-nosed ones, preferably with smooth jaws. Buy cheap tools first and duplicate the most used ones with quality.

Try to complete all high-temperature soldering before attaching any of the cast whitemetal parts. These can be attached with two-part epoxy resin such as Araldite Rapid. Ensure the surfaces to be glued are clean and free of grease.

A better alternative is to solder your white metal castings using Carrs 70 degree low melt solder and Carrs red label white metal flux. The iron should be run at a much lower heat so that you do not melt the castings. I have a domestic light dimmer switch and plug socket fixed to a piece of wood, wired up with a lead and 3 amp mains plug to the input side of the dimmer switch and the output of the dimmer switch into the plug socket (remember to continue the earth). Plug your 40 Watt iron (25 Watt iron won't work) with a clean and freshly tinned bit into this and experiment with adjusting the switch until you find the range of temperature at which the solder melts, but a scrap casting does not. **Note** as the iron is running at a lower voltage it will take longer to heat up, so when you think the adjustment is correct do check a few minutes later on another scrap casting to see that it doesn't melt. Then scribe a mark on the switch knob to indicate this position.

When attaching white metal fittings to brass the surface of the brass must be tinned with 145° solder, to allow the solder to grip. The surface of the casting at the joint should be burnished bright. The casting can then be soldered into place with 70° solder and fillets of solder run into any gaps with no risk of melting the casting.

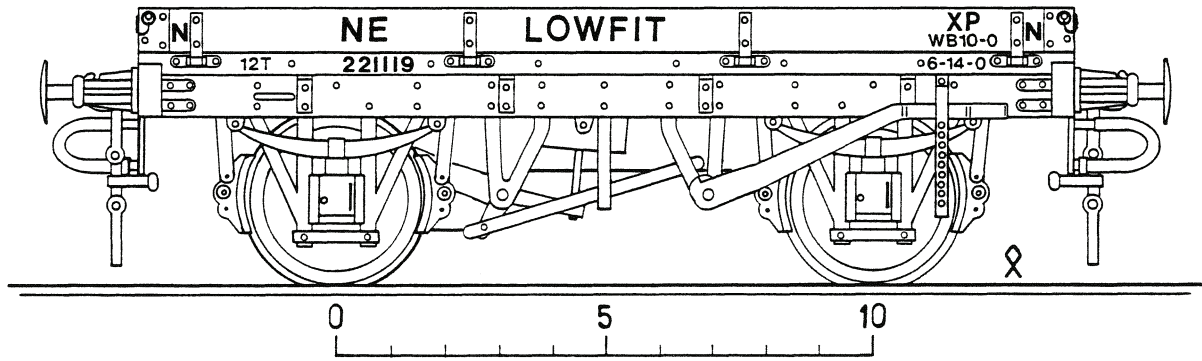

As this is a photocopy the drawing may not have reproduced exactly to 7mm scale

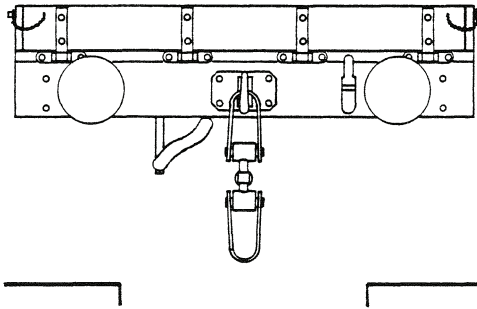

LNER Livery. Bodywork, Solebars & Buffer Beams - Red Oxide (RailMatch paints LNER freight red oxide No 625). Buffers, couplings, running gear and metalwork below solebars - black. Dirty wood floor planks. White lettering and white end of brake lever.

BR livery. Similar to LNER but British Railways used bauxite in place of the red oxide (RailMatch paints BR early freight stock bauxite No 323). The number is prefixed with E so sample numbers would be E221119 or E203160.

Transfers for LNER & BR lettering are available from the Historical Model Railway Society, Brian Webb (*volunteer sales officer*), 8 Gilpin Green, Harpenden, Herts AL5 5NR. Send SAE for list and order form or they are stocked by some specialist retailers. These are Pressfix type and you will require sheet 12 LNER goods vehicles or sheet 25 BR revenue wagon.

Prototype References. A Pictorial Record of LNER Wagons, Peter Tatlow, OPC, ISBN 0-92888-92-7, Page 68.

LNER Lowfit Wagon Parts Identification and check list

1 X 4" length 1.6mm brass rod (brake cross shafts). 1 X 6" length 0.7mm brass wire. 1 X 5" length 0.9mm brass wire. 1 X 6" length spring steel wire for buffer springing (may be tarnished). 2 X turns 29swg tinned copper soft wire (twist together to make corner chains).

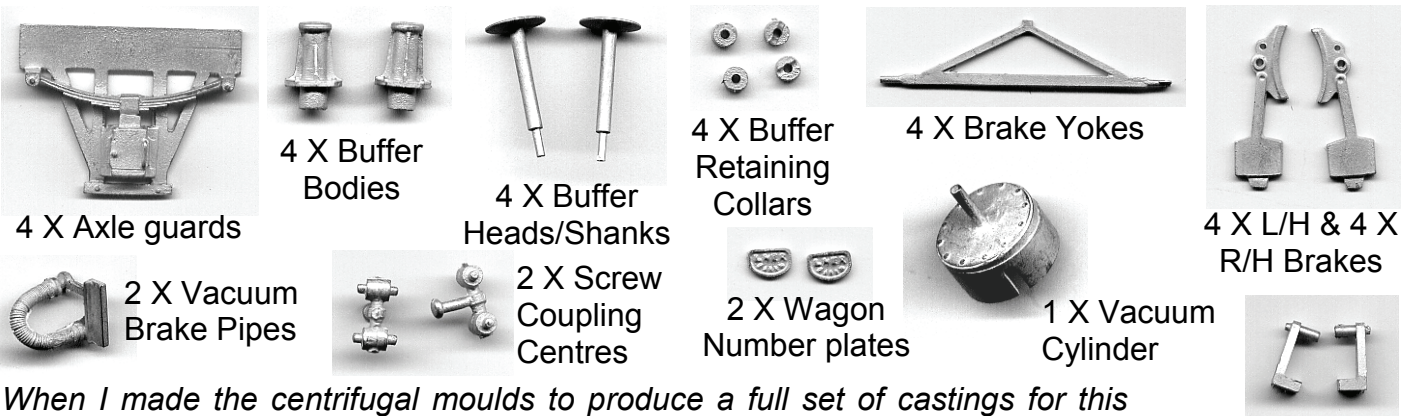

When I made the centrifugal moulds to produce a full set of castings for this wagon I took a bakers dozen approach to the number of sub masters I placed in each mould. So you should find extra castings to guard against accidents & mishaps but the quantities listed are the minimum required for the wagon.

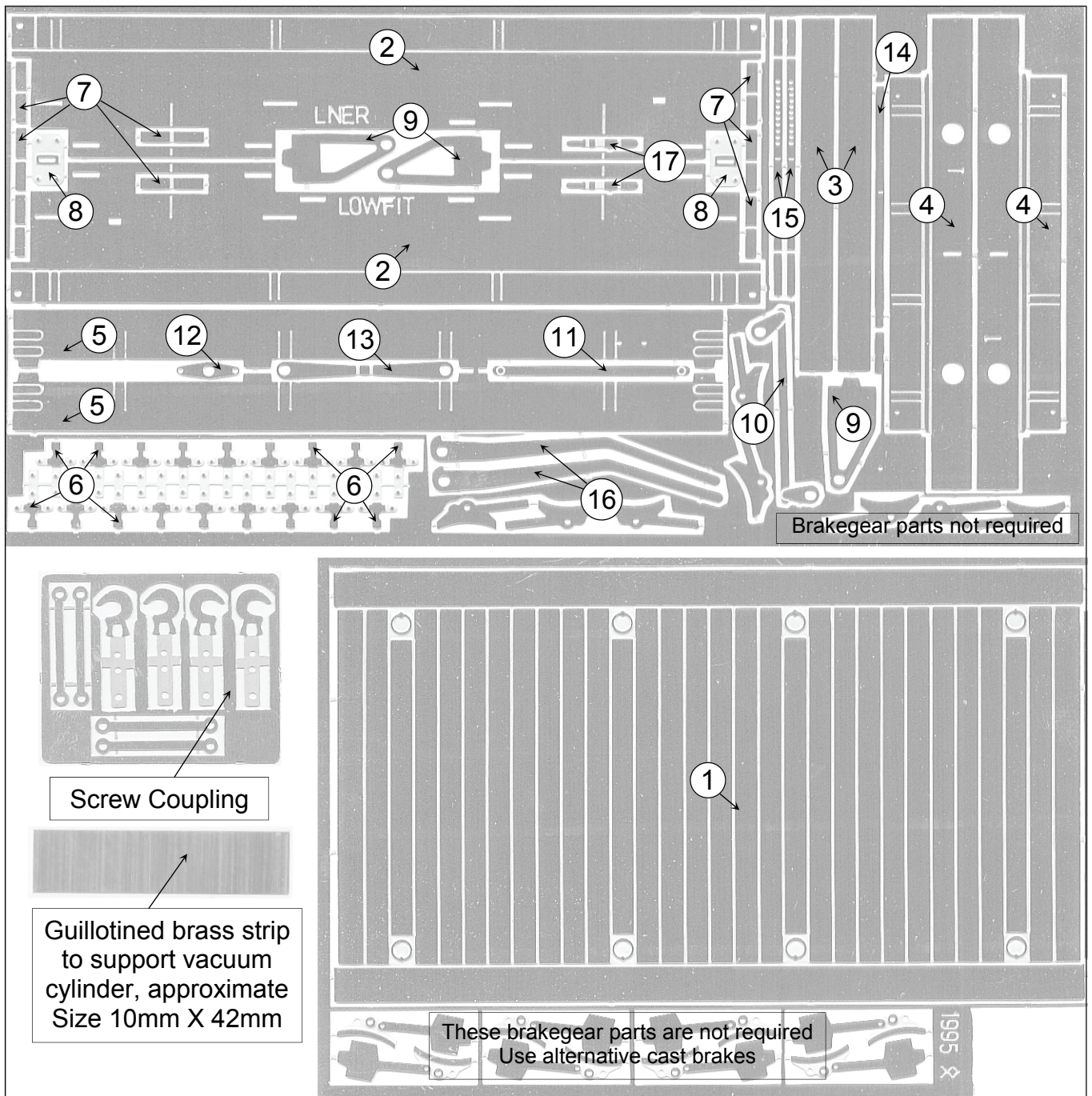

LNER Lowfit Suggested Assembly Order

1. Take the planked floor section (part 1) and note that there are push out bolt heads on the strips that run down each side. Embossing these is best achieved using a rivet forming tool. Alternatively you can use a scribe with the point rounded off slightly on an oil stone. Place the part face down onto a block of softwood and firmly press the point of the scribe down into the half etched hole. This should raise a domed bolt head on the other side of the brass etching. Then fold these strips through 90° to form the inside faces of the two side planks.

Take the two sides (parts 2), remove and keep safe the small parts that are tagged into them, note the bolt heads that require embossing and then using the fold line on the rear face fold the parts through 90°. As there is an etched line on the outside face to represent a plank joint in close proximity to the fold line on the inside face there is a risk of the part creasing as you make the fold. To prevent this I would recommend that you deepen the fold lines by pushing a sharp triangular file up them until a faint witness mark appears on the reverse side (don't widen the fold line). By deepening the fold line it reduces the amount of force required to make the fold and this should reduce the risk of distortion of the unfolded sections.

Now solder these outer sides to their inside faces with the tops level to form a double thickness plank and the underside of the wagon floor (about 1.5mm gap between to represent floorboards).

LNER Lowfit Main Assembly

Assemble parts in numbered order

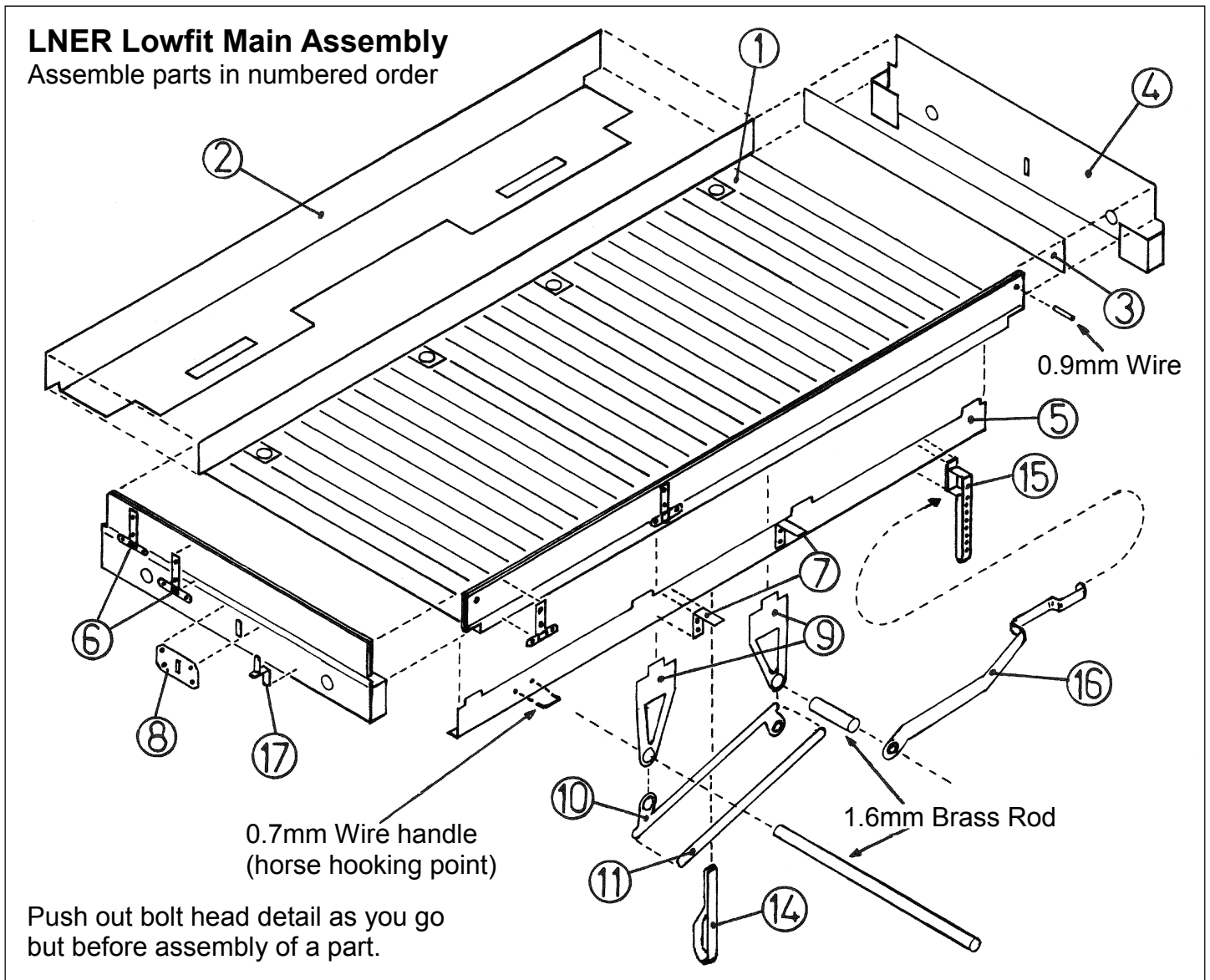

2. Take the inside faces of the end planks (parts 3) and emboss bolt heads. Also emboss the four bolts on the buffer beams/end planks (parts 4). Then solder parts 3 and 4 together to form a double thickness plank again with the top edges aligned. Make the double 90° folds to form the ends and inside of the buffer beams and offer into place on the floor/sides assembly. Hopefully you will find that the buffer beam ends and floor cut outs will help locate and position the ends between the sides so that you can solder them into position with confidence but do double check that the body does not twist during soldering.

3. Take the solebars (parts 5) emboss bolt heads and fold bottom edge through 90°. Then solder into place locating into the underside of the floor. If required file the ends slightly to achieve a snug fit between the buffer beams. Bend up from 0.7mm brass wire and fit the horse hooking points (these handles/bars were used to attach the ropes or chains for horse or capstan shunting).

4. Now fit the hinge detail (parts 6) to the sides and ends. There are etched marks to help with location. I tin the back of the hinges first and then remove them from the fret by cutting through the outer tags but leave them connected together as a block with the centre tags. I then fold over and solder the ends to give a double thickness to represent the hinge pins. Then separate into individual components and clean off any remaining ends of tags.

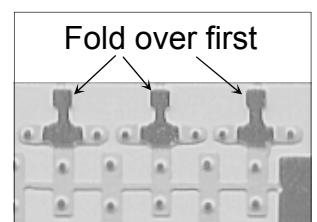

Hold the hinge in place with the end of a file and apply plenty of flux and a dry iron to the edge of the part until molten solder runs out from all the edges. Check that the hinge is firmly fixed and then clean up around the edges with a knife blade and fibre brush.

5. Take the solebar to body brackets (parts 7) emboss bolt heads and fold through 90°. Then solder to solebar and underside of body noting the etched marks to help with positioning.

6. Fit the coupling reinforcing plates (parts 8) so that they correspond with the coupling slots in the buffer beam. Ensure that the coupling slot does not get blocked with solder.
7. Fit the components of the LNER standard vacuum brake linkage with reference to the two diagrams. It takes a little thought to work out what each part of the brake gear should do but studying the drawings first should help to make sense of my words.

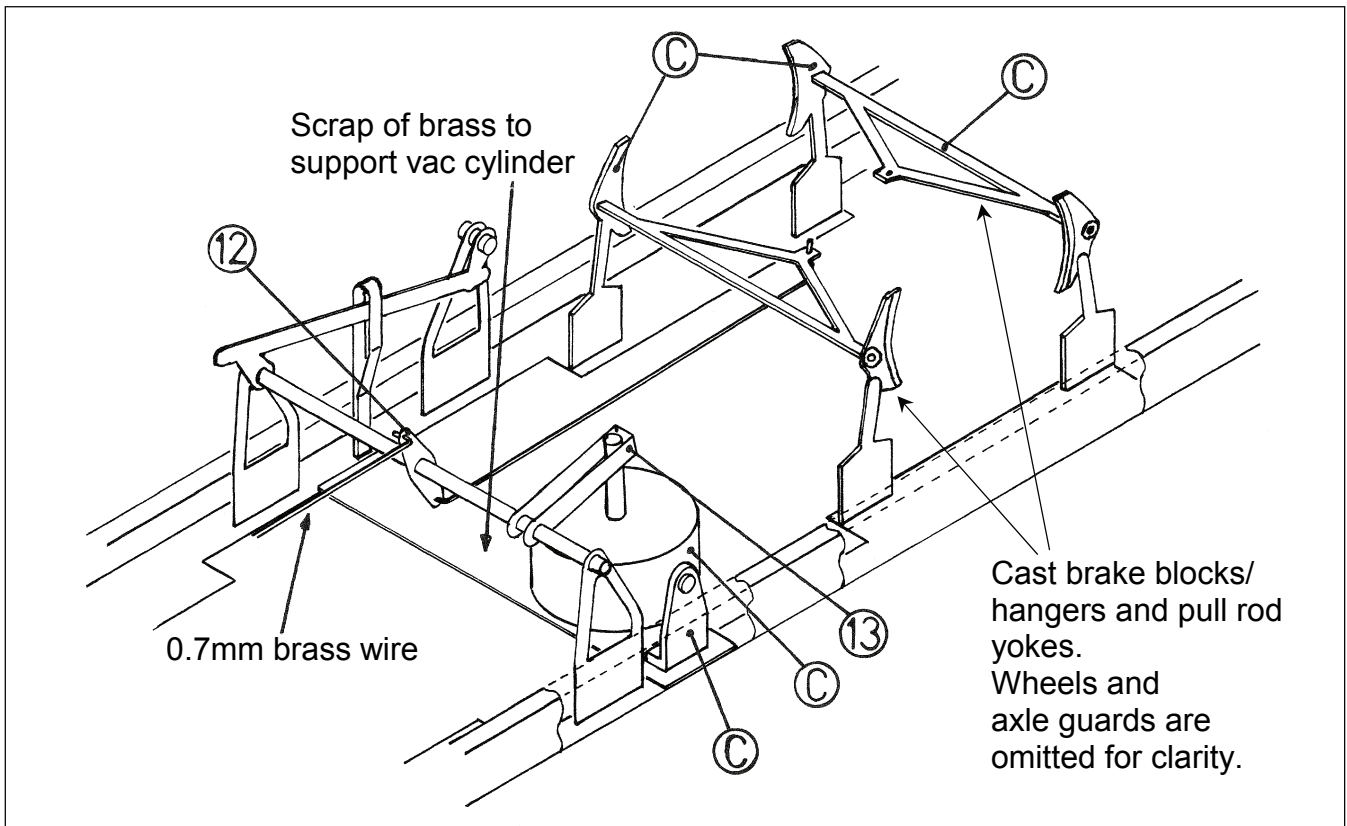

Fit two vee hangers (parts 9) opposite each other and then laminate together the two parts of the cross-link, (parts 10 and 11). Then pass a length of 1.6mm brass rod just over 2" long through the vee hangers and cross-link (don't solder rod). Now fit the third vee hanger using the cross-link and remaining brass rod to check that it is positioned correctly. Then solder this brass rod into the vee hanger, apply plenty of flux and the solder should also flow through and solder the cross-link that is spaced just behind the vee hanger. The brass rod will be trimmed to length later.

Withdraw the brass rod from the two vee hangers and file one end square. Fold up the vacuum cylinder linkage (part 13) and then tin the inside faces. Pass the brass rod back through one vee hanger, thread (part 13) over the rod and then the brake pull rod crank (part 12) then pass the brass rod through the cross link and into the second vee hanger. Now solder the brass rod into this second vee hanger so that the squared off end projects about $\frac{3}{4}$ mm. Again use plenty of flux so that the solder runs through and also solder the cross-link. Form up and fit the cross-link safety loop (part 14).

Solder a scrap of brass strip across the inside of the body to support the cast vacuum cylinder. Solder the cast supports, set at a slight angle, to the vacuum cylinder. Fit vacuum cylinder to the scrap of brass and also spot solder the outside support to the solebar. Fit the end of the vacuum cylinder linkage over the peg (peg may require two flats filing onto it) of the vacuum cylinder and also solder at the brass rod. Solder the pull rod crank (part 12) in the centre of the brass rod and at a slight angle. Hopefully reference to the diagrams will make this description clear.

8. Fit axle guards and wheel sets. My casting technology is not very sophisticated and I never seem to be able to cast axle guards cleanly, so clean out any flash between the W irons with a sharp pointed scalpel blade. File about $\frac{1}{2}$ mm off the top of the casting so that the spring ends will fit hard against the bottom of the solebar.

Drill out to 2.6mm diameter the hole to take the brass axle bearing (go carefully as you don't want to drill through the front of the axle box). This hole is formed by a small rubber peg in the mould which tends to flex as metal flows into the mould cavity and you will probably find that the hole is not quite square to the back of the axle guard. To correct this use a drill held in a hand pin vice (chuck) and by applying a gentle sideways pressure as you drill out the hole, you will be able to square it up. Then fit the axle bearing into the slightly oversize hole in the axle guard with a blob of Evostick, as this takes a little time to set you can make adjustments to the axle guards and then leave the wagon on a flat surface for the glue to set.

Slip wheel sets with the axle guards on between the solebars and tack solder each axle guard with low melt solder to the solebar. Check that the axles are parallel and the wheel centres are about 70mm apart, there are etched centre marks on the underside of the body that I find useful to eye up to. Place the wagon onto a flat surface and adjust if necessary, by re-soldering each axle guard until the wagon sits without rocking, when happy solder solid.

9. Fold up the brake pin guides (parts 15) note that the bottom 180° fold is a curved bend. Reinforce the folds with 60/40 solder and fit to solebar with the top locating in the hole on the underside of the floor. Dress the cusp off the brake levers (parts 16) to make them look a little more delicate. Then form up (note etched dots to mark the position of the handle folds), thread handle through pin guide and solder at vee hanger and pin guide. Cut excess off ends of 1.6mm brass rod and file ends square.

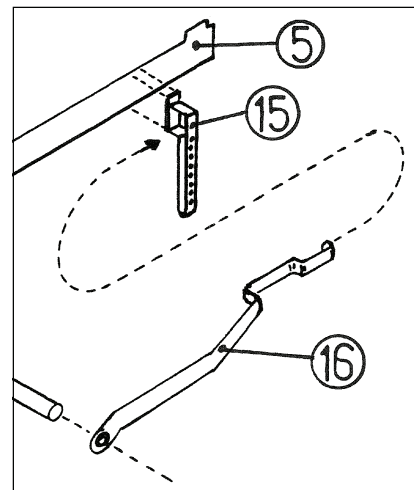

10. The brake blocks and hangers are white metal castings that are slightly different at the base to provide left and right hand pairs (ignore the etched brass brake parts). Holding the brake blocks with a crocodile clip etc, position just clear of the wheel tread and locate and solder the base into the slot on the underside of the body. Once you have a pair of brake blocks around each wheel spring the cast brake yokes between the brake hangers/blocks and spot solder at each end. Link the inside brake yokes to the pull rod crank (part 12) with 0.7mm brass wire.

11. Fold up the lamp brackets (parts 17) noting that the centre fold is a reverse fold and the brackets position is marked on the buffer beam. Before fitting, hold the top of the bracket with tweezers and apply a generous blob of flux. Then touch the side of the lamp bracket with the tip of the soldering iron coated with 60/40 electrical solder. The flux should draw the solder off the iron tip into the fold lines to reinforce them.

Now we must represent the slotted iron bars that projected from the ends through the side planks and secured the hinged sides and ends upright by means of a removable peg pushed through the slot. To prevent loss this removable peg was attached to the wagon by a ring and chain.

Solder a length of 0.9mm wire into the hole at the end of the side plank to form the bar. Then make corner chains by twisting 29swg tinned soft copper wire over a drill shank. Pass wire ring over 0.9mm brass wire and solder tail of wire into hole in end plank. Then mould twisted wire into a natural looking curve around the wagon corner and spot solder ring to brass wire. Snip off excess length of 0.9mm brass wire and dress end square to leave a bar projecting just over 1mm from the wagon side. Repeat at the other corners.

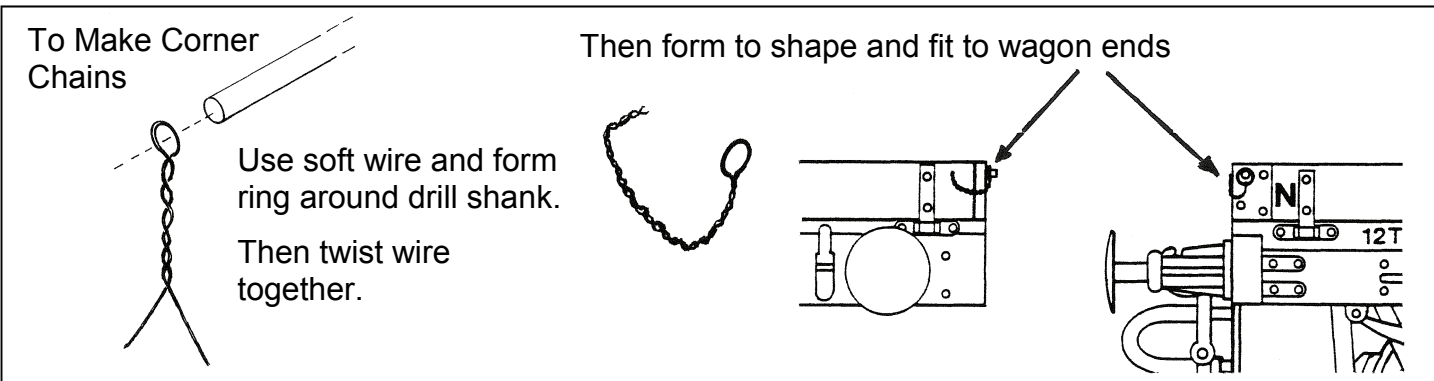

12. Drill out the buffer bodies with a 2.1mm drill to take the cast buffer head/shank. Hold the drill in a hand pin vice (chuck) and grip the buffer body between finger and thumb. Drill through the body from each end so that the hole breaks through in the middle. Use a little spot of spit on the end of the drill (some more technical people have a block of furniture polishers bees wax that they smear on the drill end) and this will help prevent the drill wandering in the white metal and breaking through the side of the buffer. Then fit shank through buffer body, snip off some of the narrow end of the shank to leave just over 1mm from the step and solder a retaining collar onto the shank. Open up holes in buffer beam slightly and fit buffers.

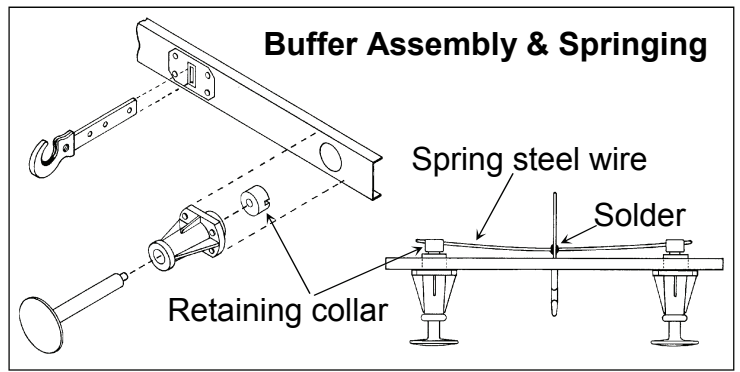

Fit the cast vacuum brake pipes mounting the top section behind the buffer beams and referring to the main drawing for exact position (about 5mm to the left of the coupling slot).



Cosmetic screw coupling. Solder both halves of each hook together and if necessary round the slot so that the link will swing freely and then using round-nosed pliers form the four links into U shapes. Dress the tops of two links with a file so that they will pivot freely in the slot in the hooks. Thread one of these links through the hook and spring the ends over the pegs on the cast centre.



Pass the coupling hook through the slot and retain it with a length of spring wire. Polish the centre of this wire with emery cloth first so that you can solder it to the coupling hook shank once you are happy that the buffers spring freely.

The final job before painting is to fit the cast wagon number plates to the solebars. The positioning of these varied but they were generally somewhere slightly to the right of the left hand axle guard. As these are not a structural part I would recommend fixing them with a spot of glue.

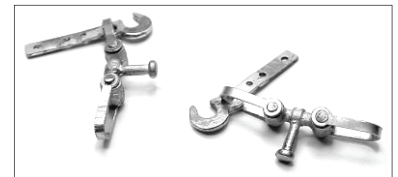

Painting is a vast subject that cannot be covered fully here. The important thing with a metal model is to get a good base coat of primer. Hopefully you have been cleaning up and washing the model at the end of each modelling session, but it will still need thoroughly cleaning before painting. I give my models a good scrub with a stiff-bristled paint brush in a sink full of hot (as hot as your hands can bear) water and cheap washing up liquid (the expensive stuff that's kind to your hands has an oil in it that will stop the paint keying to the metal). If you know somebody who works in catering and can scrounge you some industrial-strength liquid this is better still. Then rinse the model a couple of times in clean warm water and place in a dust-free box to dry.

I use car aerosol primer and Halfords grey primer is one of the best. For the best results you want to spray at room temperature (25°C) on a dry (avoid cold, damp or humid) day. I find it helps to warm the model to about 30°C (put it in the airing cupboard overnight) and I warm up the paint tin by putting it onto a radiator (about 40°C, but use your common sense as I don't want anybody blowing themselves up). I find it best to prime the model in two light coats, about 15 minutes apart and then leave for 48 hours to harden off (in the airing cupboard in a dust-free box).

I brush-paint my models with Humbrol enamel. For years I just stirred it up and painted straight from the tin but I was never completely happy with the results. Recently two things have transformed my painting. The first was a copy of Martyn Welch's book, *The Art of Weathering*, Wild Swan Publications, ISBN 1 874103 11 9. Martyn's basic techniques are very useful and almost foolproof. Martyn's method of creating worn and weathered planking for wagon floors by blending brown and grey paints to form a base. Then dry brushing darker shades to represent the wood grain is particularly effective on this type of wagon. The second thing is to mix the paint in the tin and then transfer it to a palette (a sheet of clean plasticard) with blobs of lighter and darker shades of paint surrounding the main colour. Then work the paint with the brush on the palette, slightly varying the tones of the paint. This seems to totally change the texture of the paint and the way it goes on and covers on the model.



If you have enjoyed building this kit and have been satisfied with the quality, I would be most grateful if you could recommend it to your friends and fellow modellers. Although my kits are not perfect, I try to put a lot of time and effort into producing them. If I can get extra sales of a kit through customer's personal recommendation and I find that word of mouth is the best form of advertising. This will help me to put extra time and money into developing the next kit. Hopefully this will give me more satisfied customer to recommend my kits to their friends.

If you are not happy with this kit then please tell me. Hopefully I will then be able to help and sort out any problem.

Best Regards And Happy Modelling
Jim McGeown